

DATA SHEET



T 8310-8 EN

Type 3271 Pneumatic Actuator 1400-250 cm²

Application

Linear actuators particularly suitable for attachment to SAMSON Series 240, 250, 280, 290 and 590 Valves

Actuator area	1400 cm²
Travel	250 mm

The Type 3271 Pneumatic Actuator contains a rolling diaphragm and internal springs.

Special features

- Powerful thrust at high stroking speed
- Low friction
- Various bench ranges by varying the number of springs or their compression
- No special tools required to change the bench range or reverse the direction of action
- Permissible operating temperatures from -60 to +90 °C
- Female thread on the top diaphragm case to attach an eyebolt or swivel hoist

Versions

- **Type 3271 · Pneumatic actuator** (Fig. 1), 1400 cm² actuator area, 250 mm travel

Further versions

- **Versions for other control media** (e.g. water) available on request.

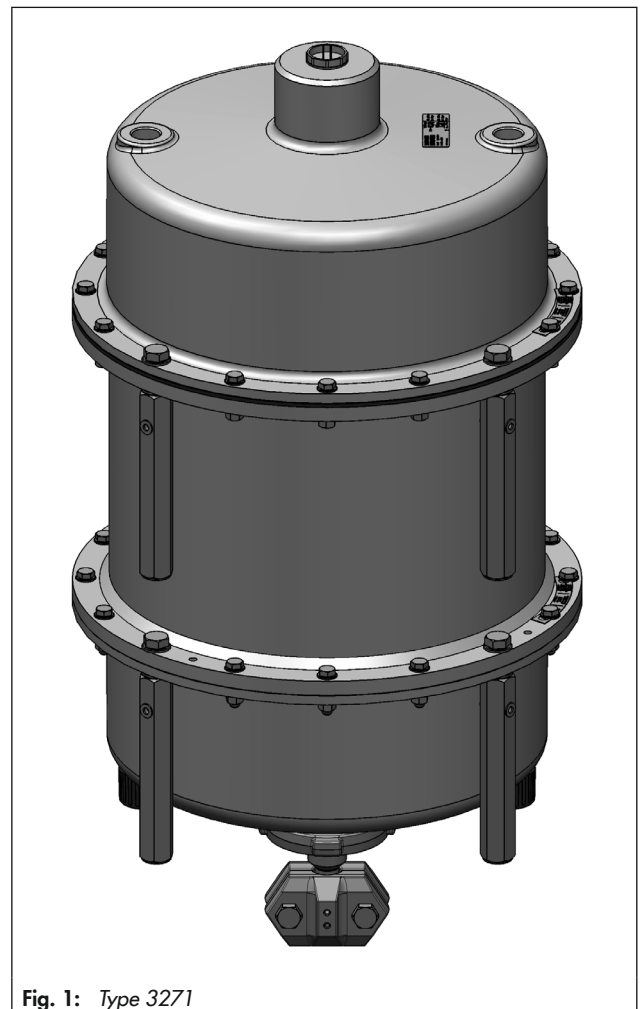

Fig. 1: Type 3271

Principle of operation

The signal pressure p_{st} creates the force $F = p_{st} \cdot A$ at the diaphragm surface A which is opposed by the springs (10) in the actuator. The bench range is determined by the number of springs used and their compression, taking into account the rated travel. The travel H is proportional to the signal pressure p_{st} . The direction of action of the actuator stem (7) depends on how the springs are installed in the actuator.

The stem connector clamps (26/27) connect the actuator stem (7) with the plug stem of the valve. A support stem (174) and support bearing (173) are screwed onto the actuator stem.

The actuators are fitted with an anti-rotation fixture (88, 127). Guide stems (170) are installed to stabilize the springs.

Direction of action

The actuator has the following directions of action:

- **Actuator stem extends (FA):** the springs cause the actuator stem to move to the lower end position when the diaphragm is relieved of pressure or when the supply air fails.
- **Actuator stem retracts (FE):** the springs cause the actuator stem to retract when the diaphragm is relieved of pressure or when the supply air fails.

Throttling or on/off service

In throttling service, the Type 3271 Pneumatic Actuator can be used for supply pressures up to max. 6 bar.

In on/off service and special actuators for throttling service, the supply pressure must be limited.

Accessories

The pneumatic actuator has a female thread on the top diaphragm case to allow an eyebolt or swivel hoist to be screwed into it. The eyebolt can be used to vertically lift the actuator and is included in the scope of delivery. The swivel hoist is designed for setting a control valve assembly upright or for lifting the actuator without valve. The swivel hoist can be ordered (accessories).

Actuator area	Item no.	
	Ring bolt (DIN 580)	Swivel hoist
1400 cm ²	8325-1101	8442-1019

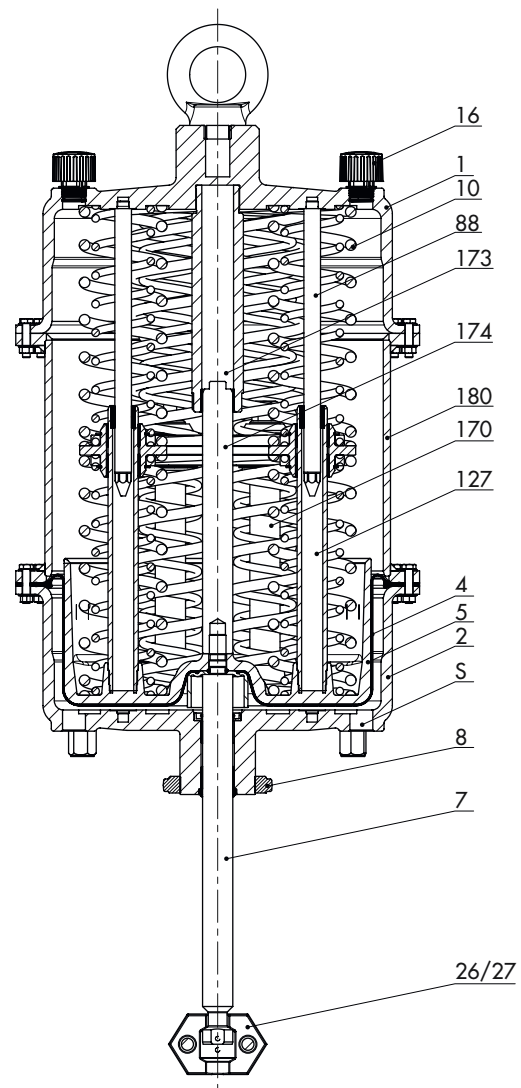

- 1 Top diaphragm case
- 2 Bottom diaphragm case
- 4 Diaphragm
- 5 Diaphragm plate
- 7 Actuator stem
- 8 Ring nut
- 10 Spring
- 16 Vent plug
- 26/27 Stem connector clamp
- 88 Rod (anti-rotation fixture)
- 127 Pipe (anti-rotation fixture)
- 170 Guide stem
- 173 Support bearing
- 174 Support stem
- 180 Distance ring
- S Signal pressure connection

Fig. 2: Functional diagram of pneumatic actuator

Table 1: Technical data**Table 1.1: Type 3271 Pneumatic Actuator**

Version	cm²	1400
Travel	mm	250
Max. supply pressure		6 bar ¹⁾
Permissible ambient temperatures		Diaphragm material NBR: -35 to +90 °C ^{2) 3)}
		Diaphragm material PVMQ: -60 to +90 °C ³⁾
Degree of protection		IP 54 ⁴⁾
Materials		
Actuator stem		1.4548.4
Actuator stem sealing		NBR
		PVMQ
Housing and associated ambient temperature		EN-GJS-400-15: up to +90 °C A352 LC3: -60 to +90 °C

¹⁾ Observe supply air restrictions.

²⁾ In on/off service, lowest temperature restricted to -20 °C

³⁾ Install vent plug (▶ AB 07) for temperatures below -20 °C.

⁴⁾ The pneumatic actuators do not pose any risk in the sense of the protection requirements described in DIN EN 60529. The IP rating depends on the connecting parts used on the pressurized side and the spring chamber side of the actuator. In this case, components (air vents as well as valves accessories, such as solenoid valves, positioners etc.) must be used that comply with the requirements. The maximum rating that can be achieved with the standard air vent is IP 54 ▶ AB 07. Depending on the IP rating of the valve accessories, a maximum rating of IP 66 can be achieved for an actuator with air purging of the actuator spring chamber.

Table 2: Bench ranges

All pressures in bar (gauge) · Pretensioned springs cannot be used with the direction of action “actuator stem retracts” for Series 240, 250, 280, 290 and 590 Valves.

Actuator type	Actuator area in cm ²	Rated travel in mm	Travel volume at rated travel in dm ³	Dead volume in dm ³	Max. travel in mm ¹⁾	Bench range in bar (Signal pressure range at rated travel)	No. of springs	Spring force at 0 mm travel in kN ²⁾	Spring force at rated travel in kN ²⁾	Thrust in kN ²⁾ at rated travel and supply pressure in bar of					
										1.4	2.0	3.0	4.0	5.0	6.0
3271	1400	250	35	5	250	0.8 to 2.55	16	11.2	35.7	-	-	6.3	20.3	34.3	48.3
						1.2 to 3.8	24	16.8	53.2	-	-	-	-	16.8	30.8

¹⁾ Based on lower bench range value, not taking zero travel (to unseat the plug) into account (see Table 3).

²⁾ The forces specified relate to the bench range.

Table 3: Dimensions and weights

Actuator area	cm ²	1400
Travel	mm	250
Height	H ¹⁾	805
	H'	805
	H _{rated} FA	415
	H _{max} FA	420
	H _{max} FE	170
	H6	85
	H7 ²⁾	110
Diameter	ØD	534
	ØD2	40
Ød (thread)		M100x2
Pneumatic connection (optional)	a	G 1/1 NPT
Weight		
Approx.	kg	417

- 1) In versions in which the lifting eyelet is welded directly onto the housing, H' and H are identical. The value H' applies.
 2) Height of eyebolt according to DIN 580. Height of the swivel hoist may differ.

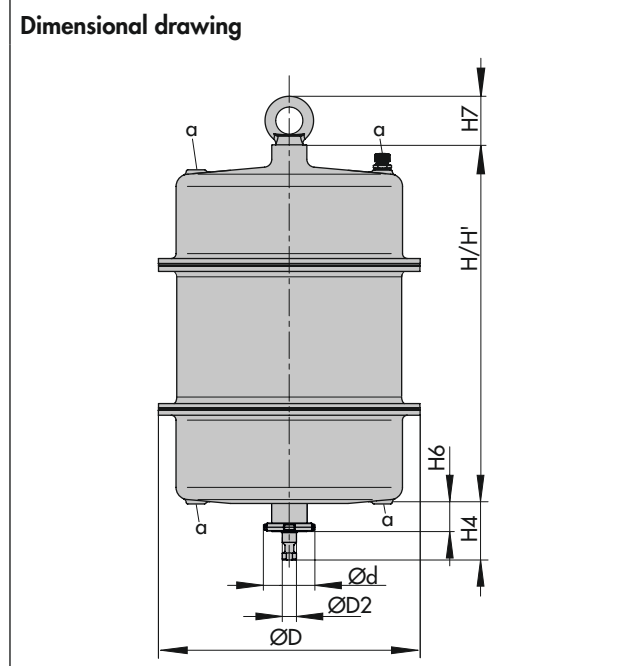

Ordering text

Actuator Type 3271
 Actuator area ... cm²
 Travel ... mm
 Signal pressure range ... bar
 Direction of action Actuator stem extends (FA)
 Actuator stem retracts (FE)
 Signal pressure connection G .../... NPT
 Rolling diaphragm NBR/PVMQ

List of documentation

Device type	Actuator area in cm ²	Data sheet	Mounting and operating instructions
Types 3271 and 3277 Pneumatic Actuators	120	▶ T 8310-1/4/5/6	▶ EB 8310-1
	240 · 350 · 700		▶ EB 8310-6
	175v2 · 350v2 · 750v2		▶ EB 8310-5
	355v2		▶ EB 8310-4
Type 3271 Pneumatic Actuator	1000	▶ T 8310-2/7	▶ EB 8310-2
	1400-120 · 2800 · 2 x 2800		▶ EB 8310-7
	1400-60	▶ T 8310-3	▶ EB 8310-3
	1400-250	Included in this data sheet	▶ EB 8310-8